

Electricity

Chapter 20B





How Do Materials Become Charged? Review

Material A

+1 +1
+1 +1
+1 +1

Material B

+1 +1
+1 +1

Material A has 6 e- & B has 4 e-. Show the net charge of the materials?



How Do Materials Become Charged? Review

Material A

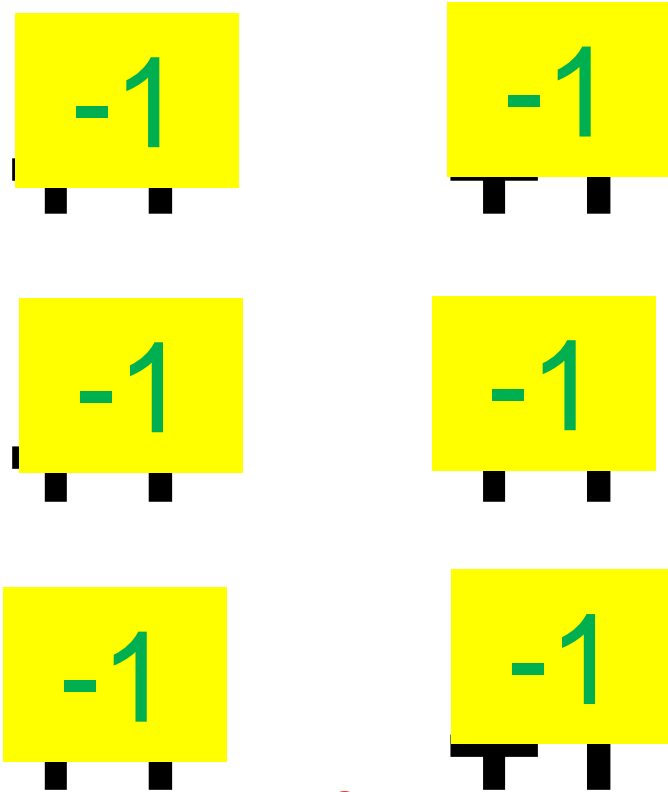

$$\begin{array}{r} +6 \\ -6 \\ \hline 0 \end{array}$$

Material B

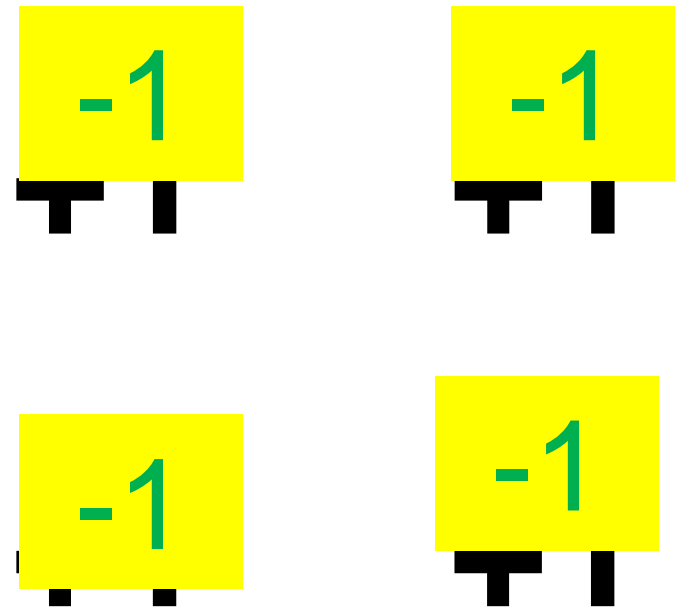

$$\begin{array}{r} +4 \\ -4 \\ \hline 0 \end{array}$$

Material A has 6 e- & B has 4 e-. Show the net charge of the materials?



How Do Materials Become Charged? Review

Material A

+1

+1

+1

+1

+1

+1

Material B

+1

+1

+1

+1

Initially Material A has 6 e⁻ & B has 4 e⁻. 2 e⁻ transfer to Material B.
Show the overall net charge of the materials after the transfer of e⁻.



How Do Materials Become Charged? Review

Material A



$$\begin{array}{r} +1 \\ +6 \\ \hline -4 \\ +2 \end{array}$$

$$+1 \rightarrow 2e^-$$

Material B



$$\begin{array}{r} +4 \\ -6 \\ \hline -2 \end{array}$$

Initially Material A has 6 e⁻ & B has 4 e⁻. 2 e⁻ transfer to Material B. Show the overall net charge of the materials after the transfer of e⁻.

What is the voltage if the resistance is 3 ohms and the current is 3 amps? What law applies?



A

G

E

S

The attractive or repulsive effect an electric charge has on other charges in the space around it is the charge's
electric force ... electric field ... static electricity ... static discharge

What is the voltage if the resistance is 3 ohms and the current is 3 amps? What law applies?



A *voltage*

G $3 \Omega; 3 A$

E $V = I \times R$ (*Ohms Law*)

S $V = I \times R = 3 \text{ amps} \times 3 \text{ ohms} = 9 \text{ volts}$

The attractive or repulsive effect an electric charge has on other charges in the space around it is the charge's

electric force ... **electric field** ... static electricity ... static discharge



Which of the following materials is a good conductor of electric current?

Wood ... glass ... air ... Iron

If a piece of wire has a certain resistance, which wire made of the same material will have a lower resistance?

a hotter wire ... a thicker wire ... a longer wire ... a thinner wire

What does the voltage between two points in an electric field represent?

- a. the total kinetic energy
- b. the difference in mechanical energy
- c. the difference in potential energy
- d. the electrical energy



Which of the following materials is a good conductor of electric current?

Wood ... glass ... air ... **Iron**

If a piece of wire has a certain resistance, which wire made of the same material will have a lower resistance?

a hotter wire ... **a thicker wire** ... a longer wire ... a thinner wire

What does the voltage between two points in an electric field represent?

- a. the total kinetic energy
- b. the difference in mechanical energy
- c. the difference in potential energy**
- d. the electrical energy

Focus Questions



1. Distinguish between static electricity and circuits.
2. Describe, draw, and explain the types of circuits (series, parallel, combination).
3. Recognize practical applications of electric force & circuits (transmission, overloading).
4. Calculate electric power (e.g. appliances).
5. Describe the workings of common electric devices.

Static Electricity

- Generated by friction, e.g. rubbing two materials against each other.
- Ordinarily, atoms are 'uncharged' (neutral), but they can lose or gain electrons through friction.
- The loss of electrons will produce a positively charged material (due to excess protons, deficiency of electrons).

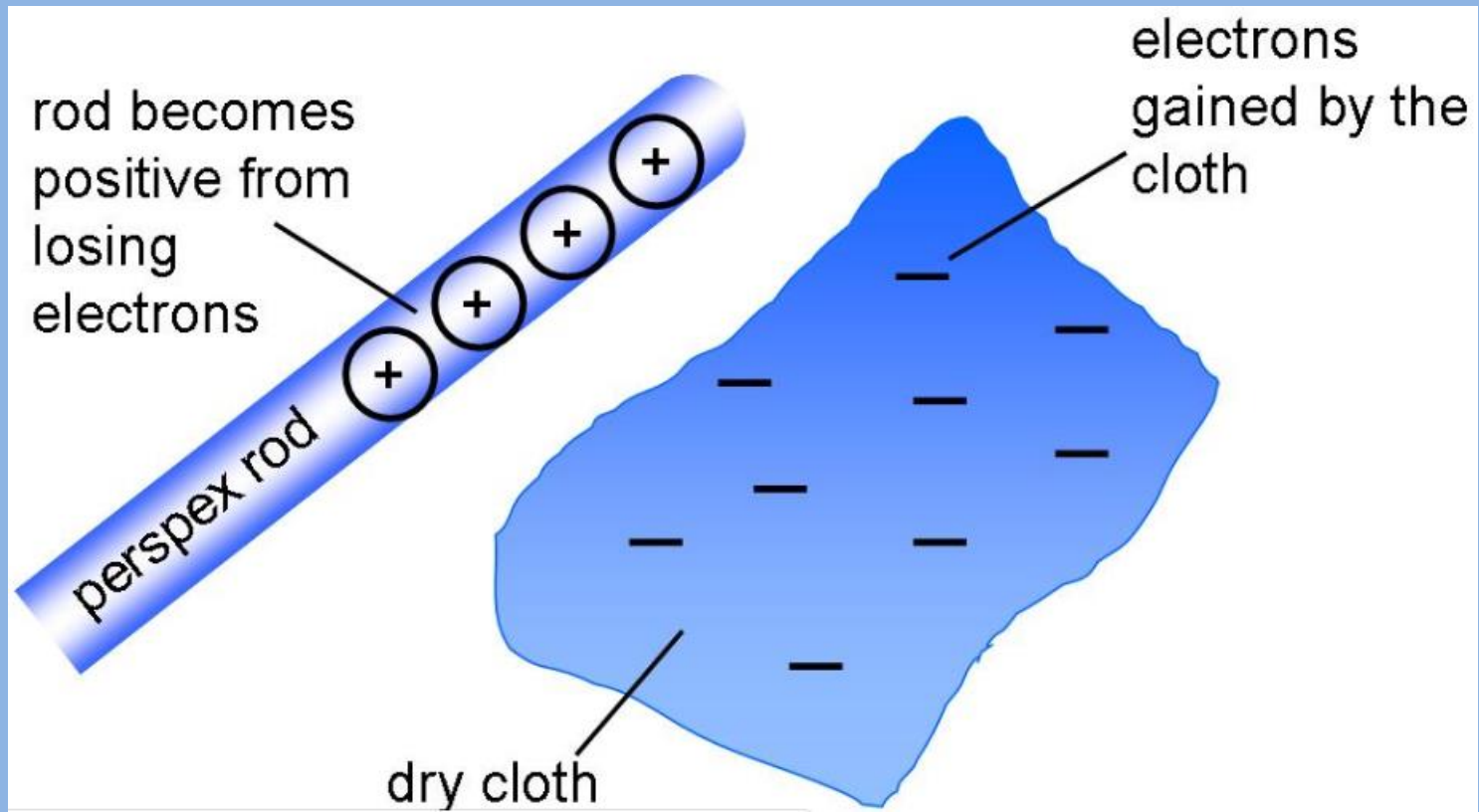

Static Electricity

The substance that gains the electrons becomes negatively charged (excess electrons).

- The phenomenon of static electricity is achieved when there is a separation of positive and negative charges.

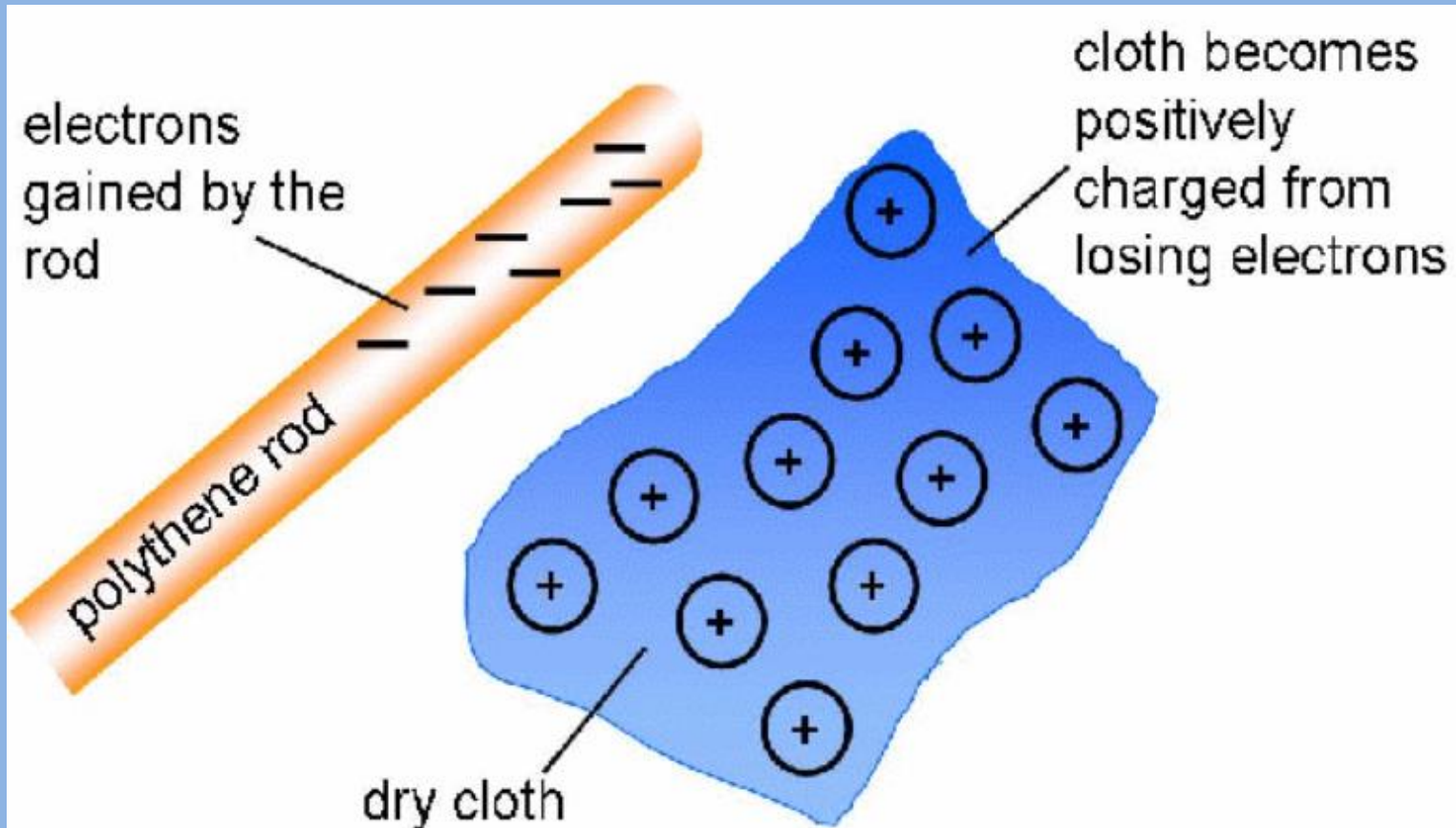

Electric charge is responsible for clothes that stick together when they are removed from a dryer.



Electricity

Static Electricity vs. Electric Current

Positive & negative charges build up, allowing electrons to jump from atom to atom, releasing energy in a one time event.

Static electricity is a one time event.



Lightning, scuffing one's feet and touching metal

Alternating or Direct current (usually electrons) that flows constantly.

Electric current is a constant flow.

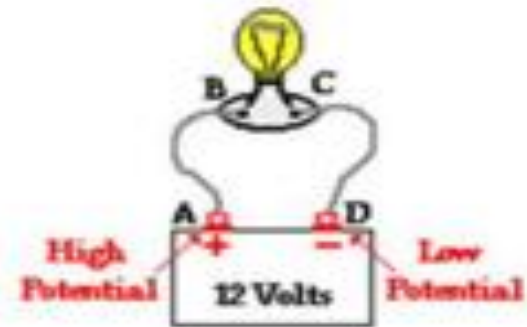

Current is broken up by a gap in the circuit (e.g. switch).

Electric Circuits

Any path along which electrons can flow is an electrical circuit. For a continuous flow of electrons, there must be a complete circuit with no gaps.

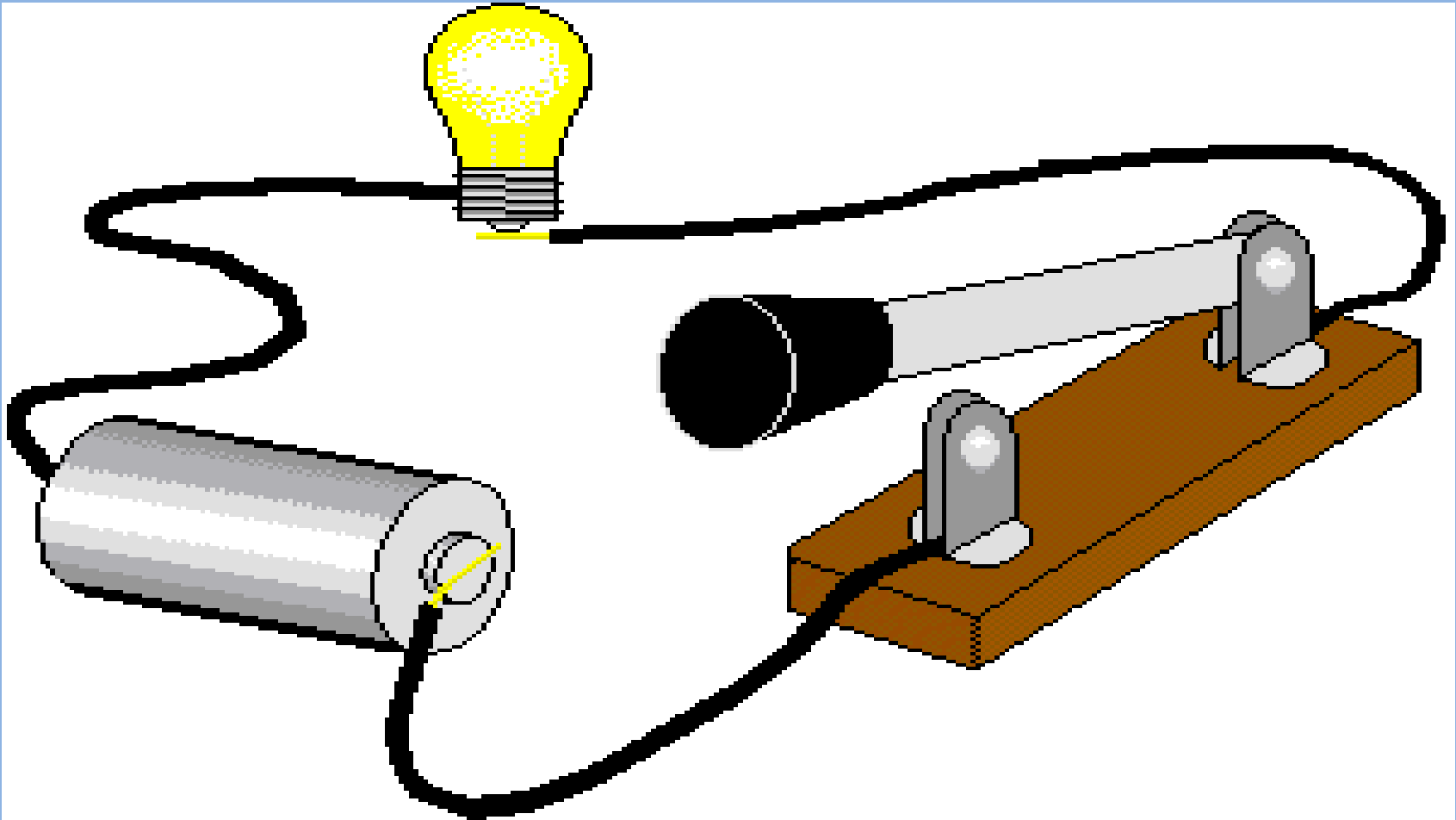

Electric Circuits

A gap is usually provided by an electric switch that can be opened or closed (turned on or off) to either cut off or allow energy flow.

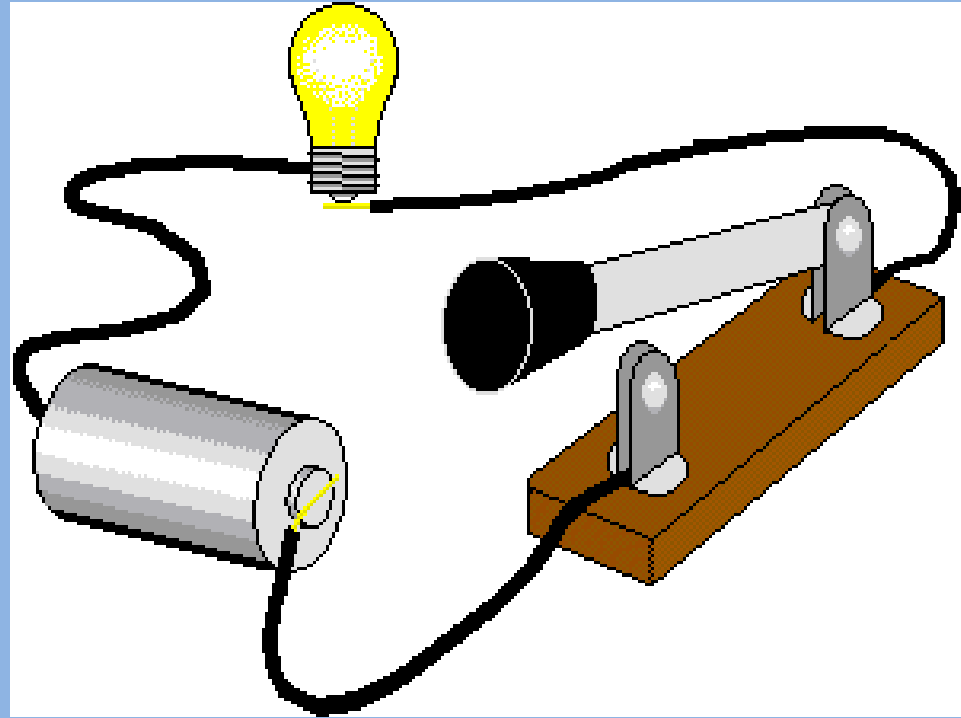

Circuits usually contain a switch, a potential or voltage source (e.g. battery), a current guide (wire), and a resistor (e.g. light).

Four Parts of the Circuit

Energy Source

Provides the "push" that makes current move around a circuit.

Load

Converts electrical energy to another form (in this case, light and heat).

Wires

Connect the energy source and load.

Switch

Opens and closes the circuit.

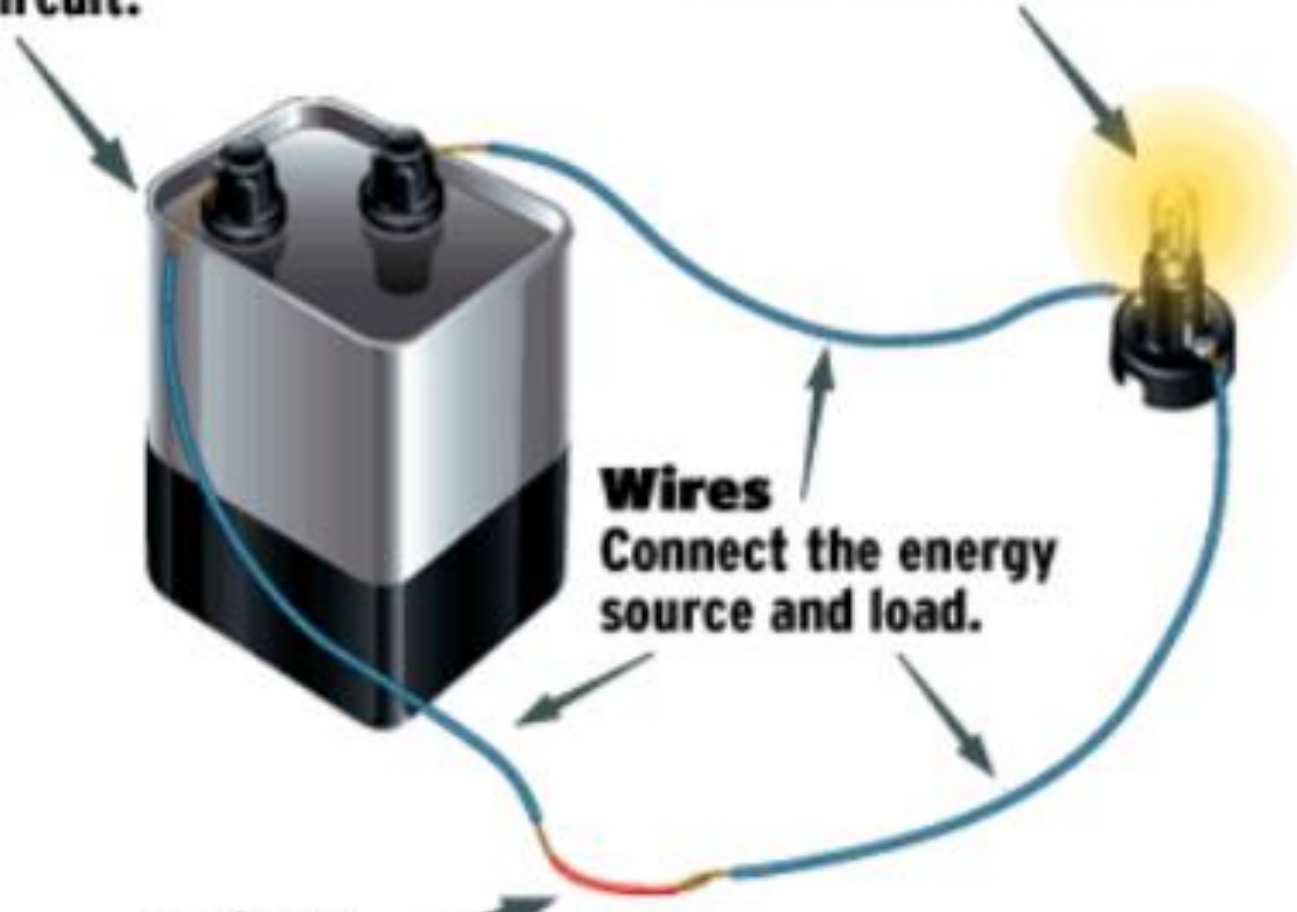

Types of Circuits

Can you see the difference between the circuits? When are each type of circuit used?

Series Circuit

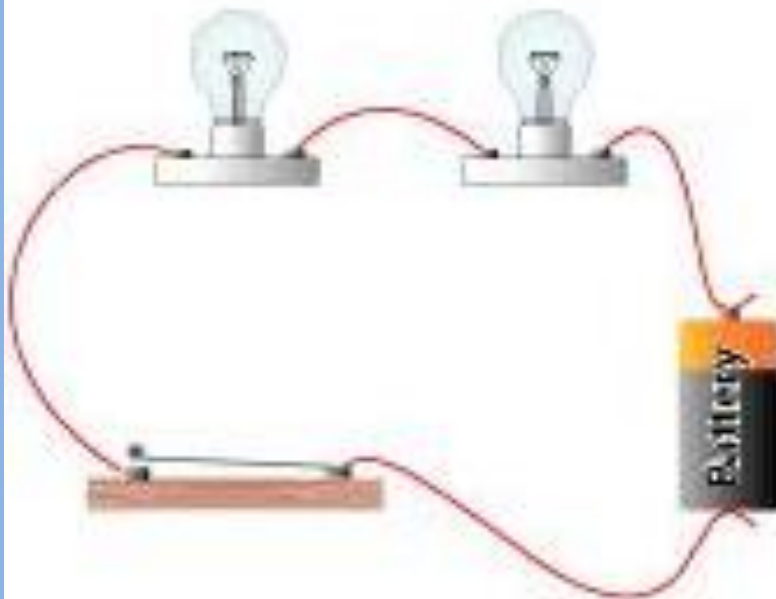

Parallel Circuit

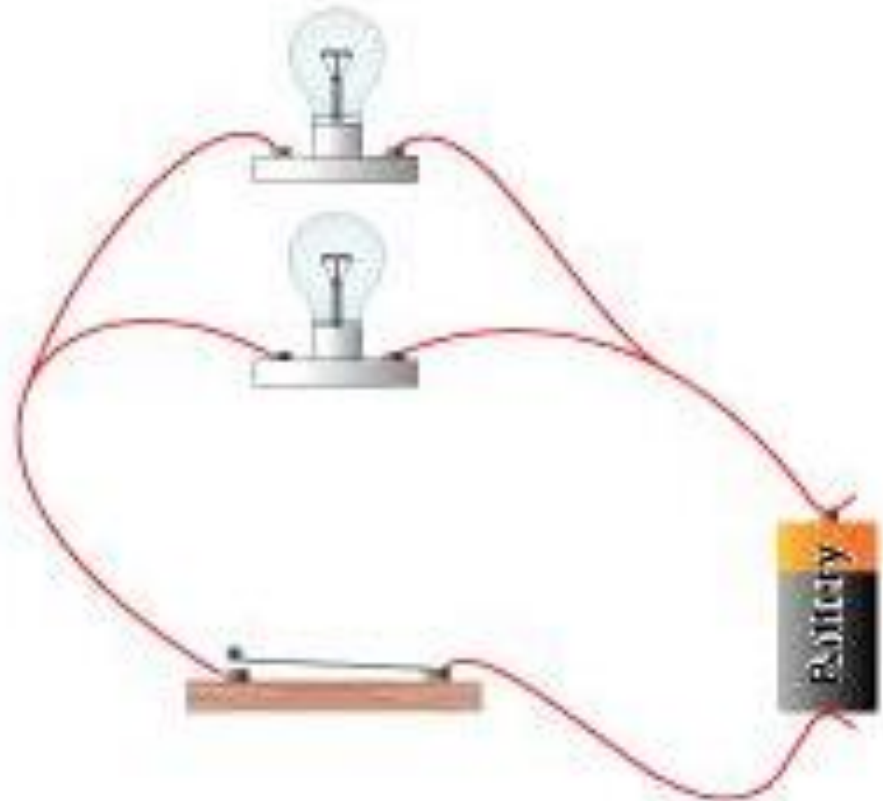

Series Circuits

A series circuit has one path that each charge can follow.

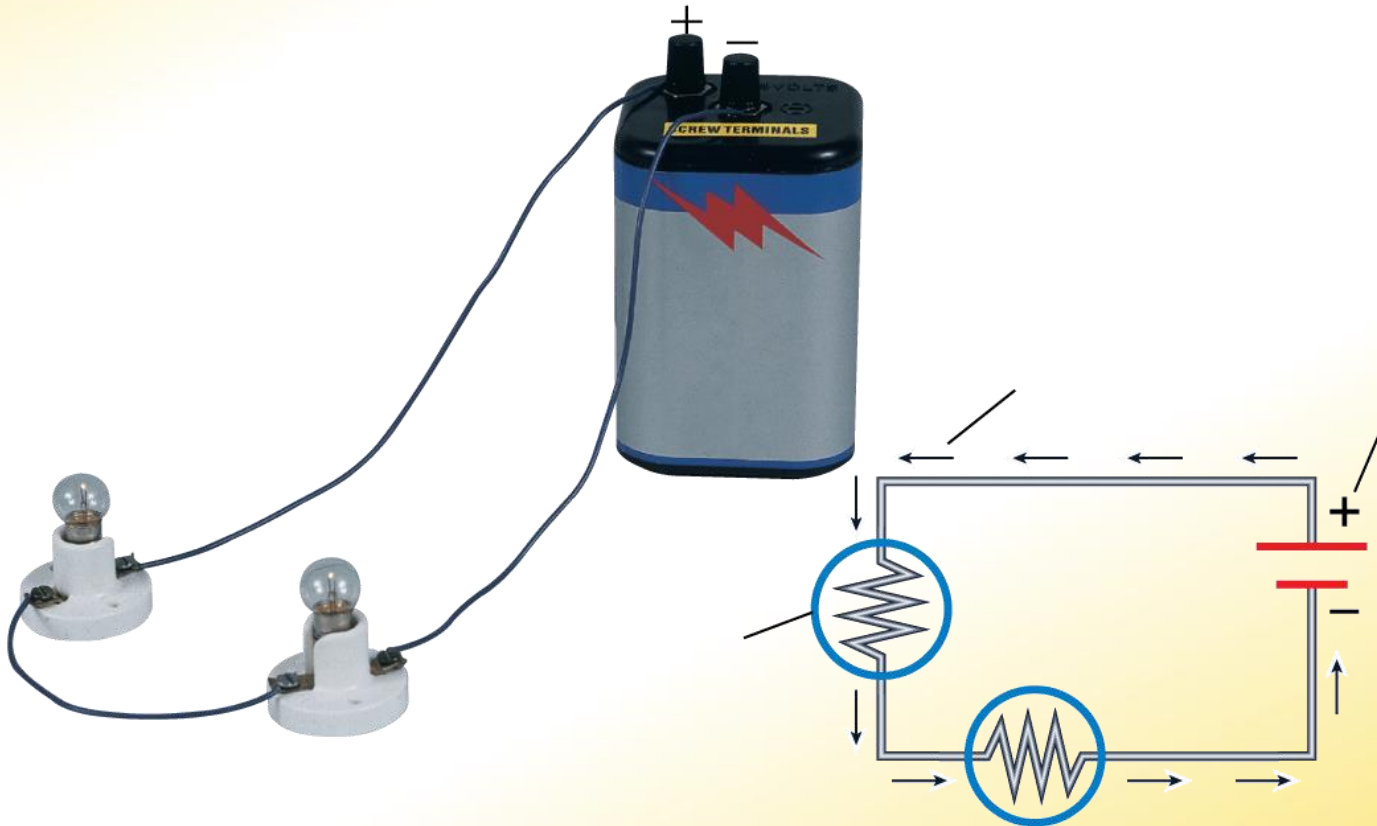

Series Circuits

An electric circuit in which electrical devices are connected in **ONE loop**, and the **same electric current (I)** exists in all **resistors (R)** or loads.

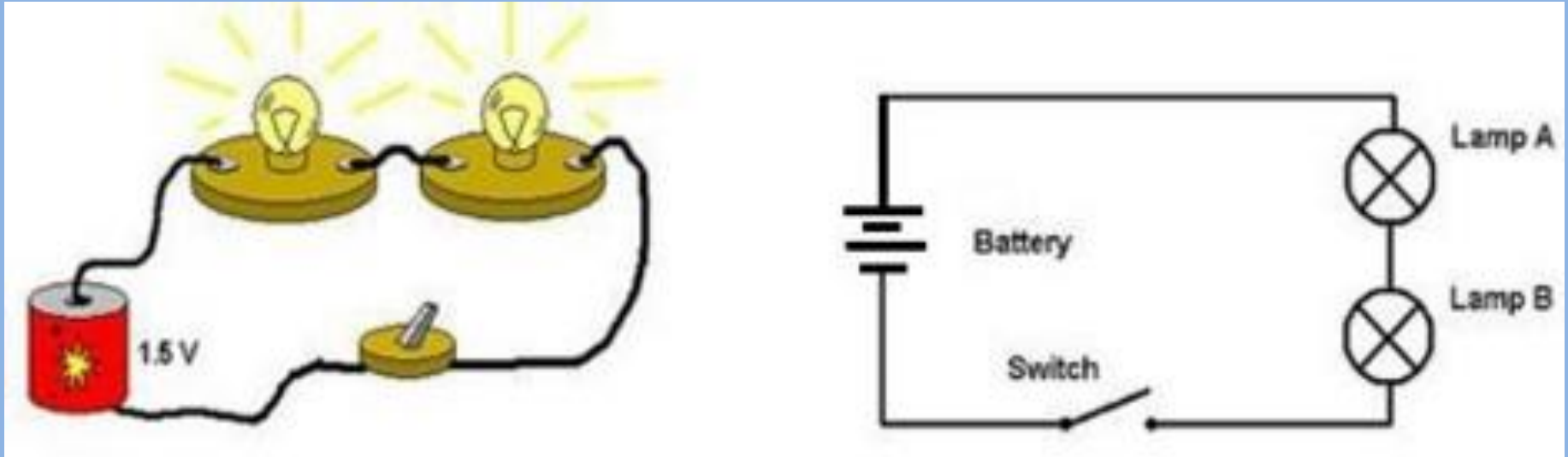

Notice the symbols in the circuit.

A flashlight is a common example of a series circuit.

Series Circuits



The amount of current (amperage) that flows across each resistor is the same. What happens if you add more resistors (e.g. lights, toaster, etc.)

Often Christmas lights are arranged in a series circuit. What is the problem with this?



Series Circuits



The amount of current (amperage) that flows across each resistor is the same. What happens if you add more resistors (e.g. lights, toaster, etc.)

[The more resistors you add, the dimmer each one gets.]

Often Christmas lights are arranged in a series circuit. What is the problem with this?

[If one light blows, all of the lights go out.]



Parallel Circuits

A parallel circuit has more than one path each charge can follow.

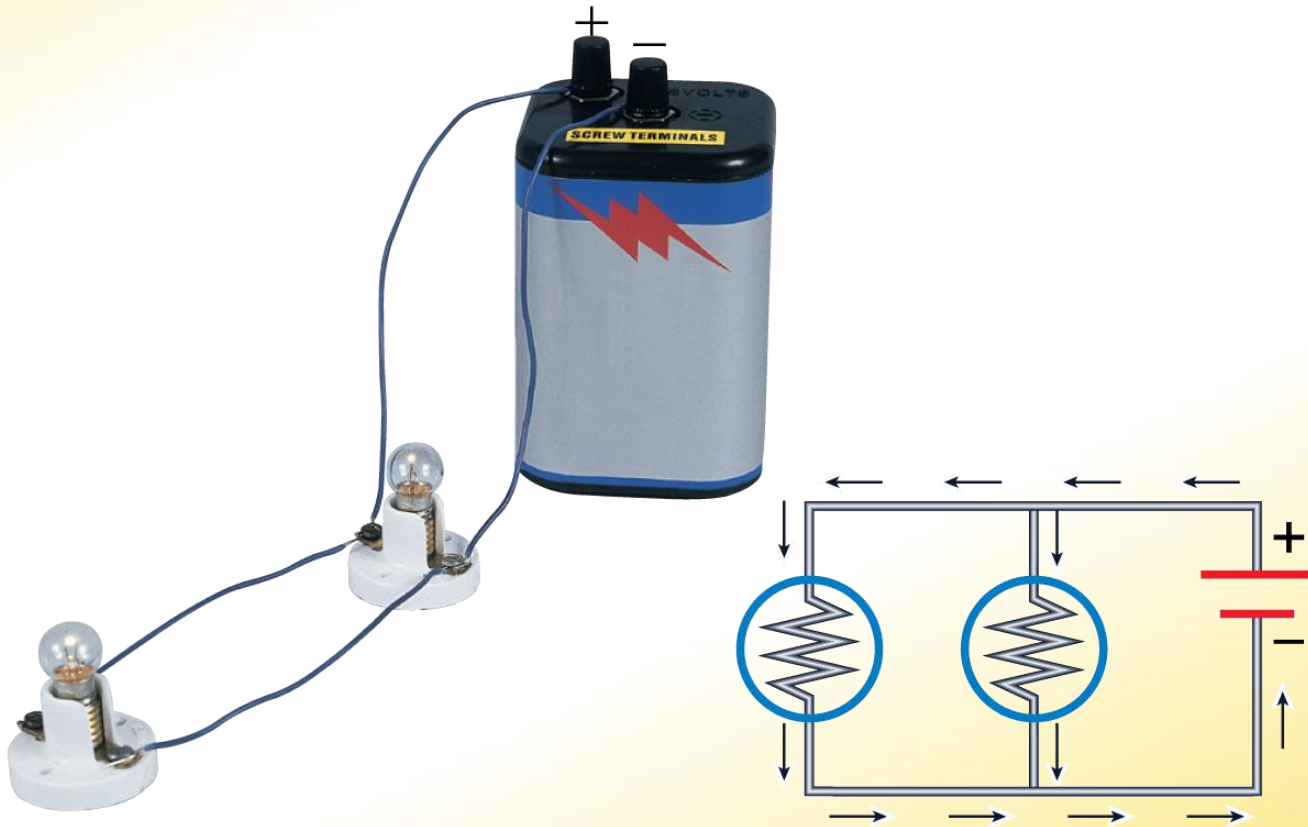

Parallel Circuits

Most circuits in a house are parallel. Even if one device stops working, the others will still work.

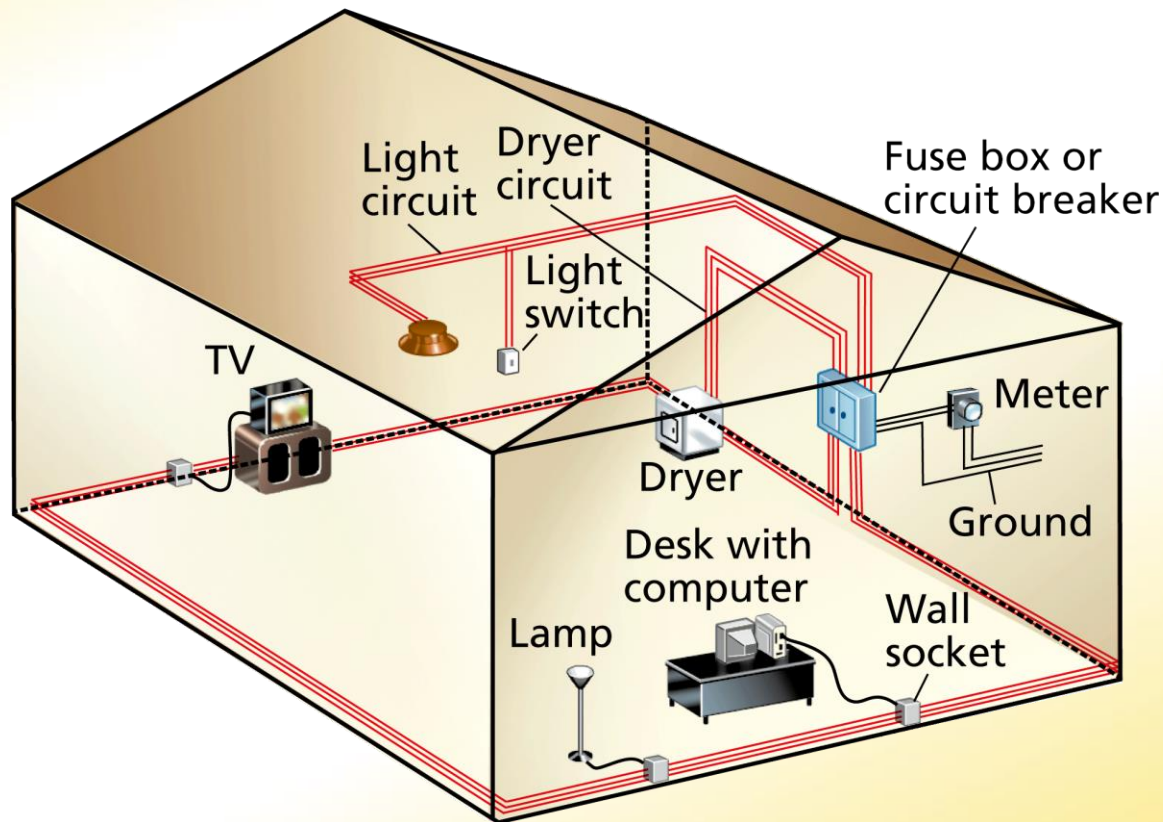

Parallel Circuits

An electric circuit in which electrical devices are connected in such a way that the **same voltage (V)** acts across each electrical device and any one of electrical devices completes the circuit **independently** of all the others; **2 or more branches**.

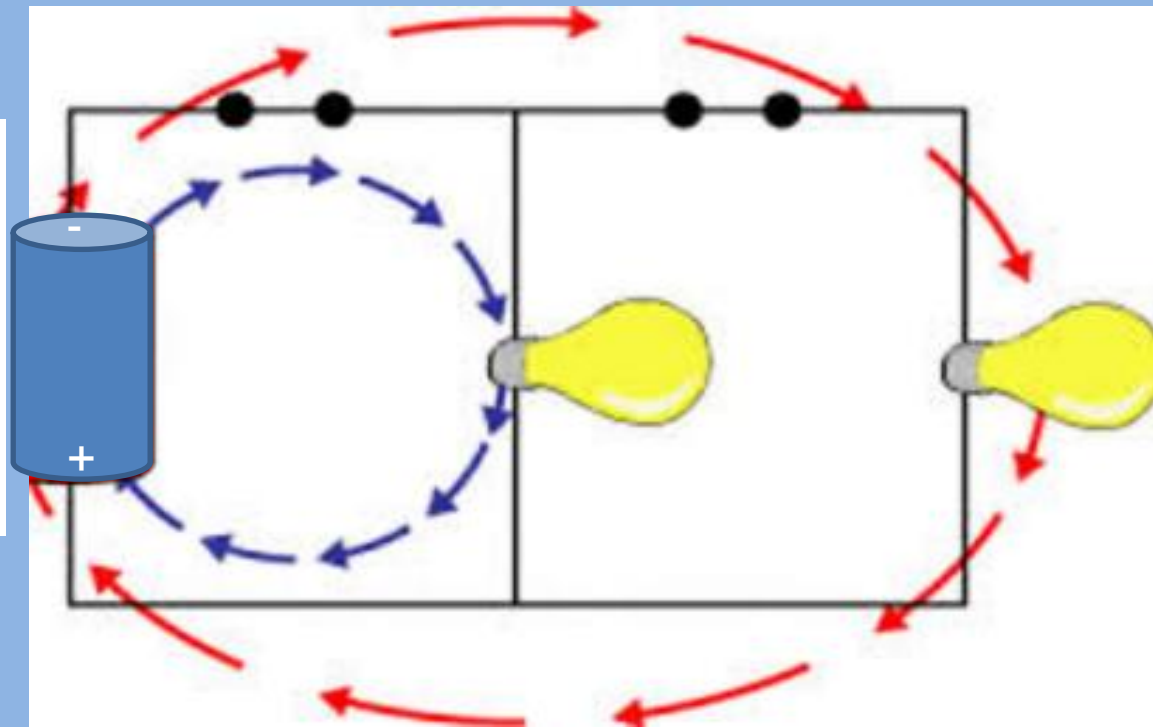
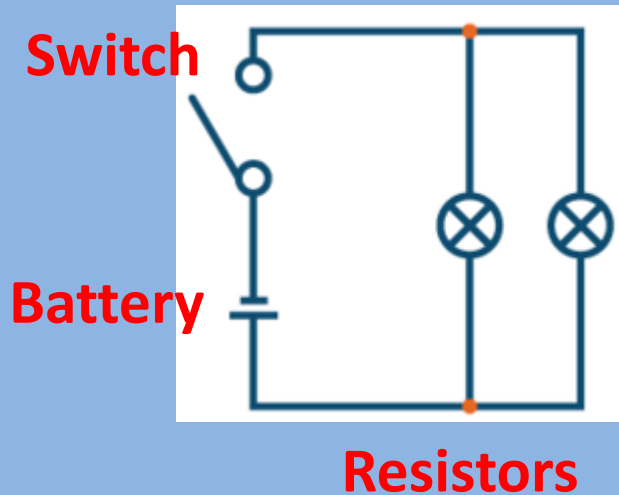

Advantages of Parallel Circuits

Every unit that is connected in a parallel circuit gets equal amount of **voltage (V)**.

Parallel circuits are used in cases of multiple loads.

It becomes easy to connect or disconnect a new element without affecting the working of other elements.

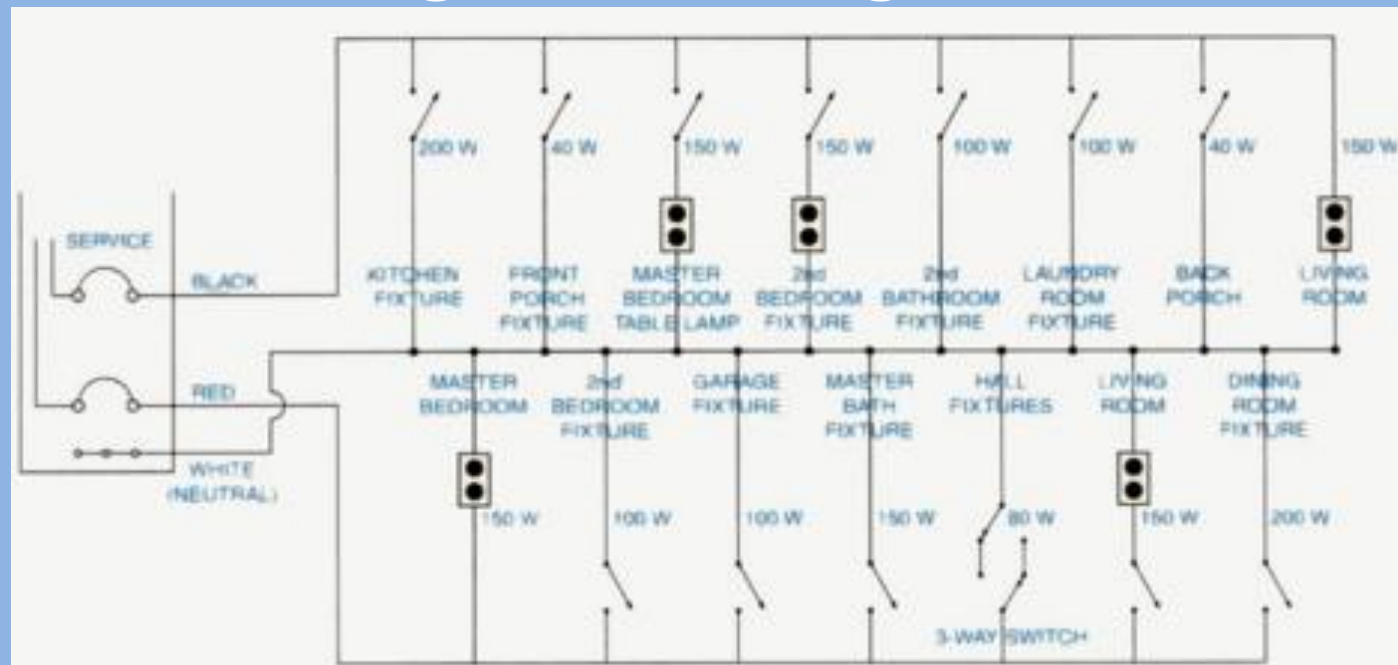
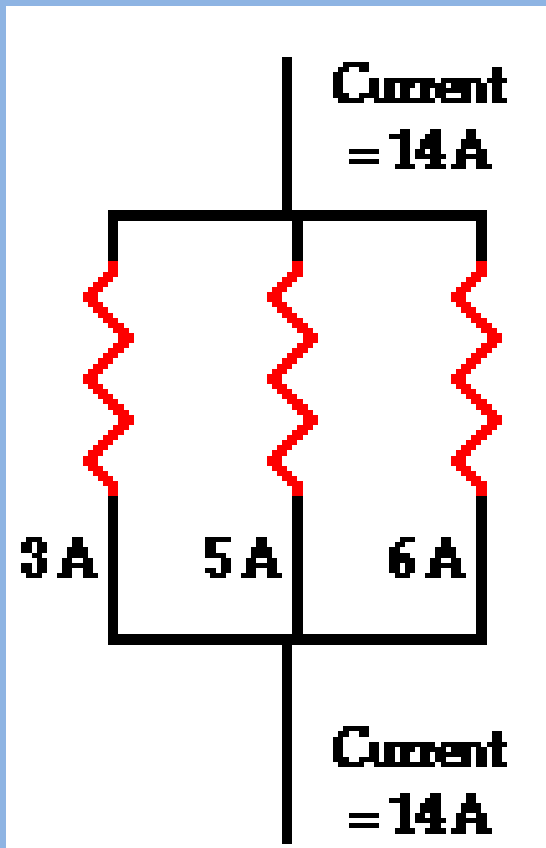

Fig. 31-5 ■ Typical breakdown of lighting loads for one circuit.

Advantages of Parallel Circuits

Notice in the diagram that the current outside the 3 branches on each side is 14A, and the total current within the 3 branches adds up to 14 A.



If any one of those branches “goes down” the other branches continue to operate since the **voltage (V)** is equal everywhere in a parallel circuit.

Ohm's Law & Parallel Circuits

$$V = IR \quad \dots \text{each branch gets } 60 \text{ V}$$

$$I_1 = \Delta V_1 / R_1$$

$$I_2 = \Delta V_2 / R_2$$

$$I_3 = \Delta V_3 / R_3$$

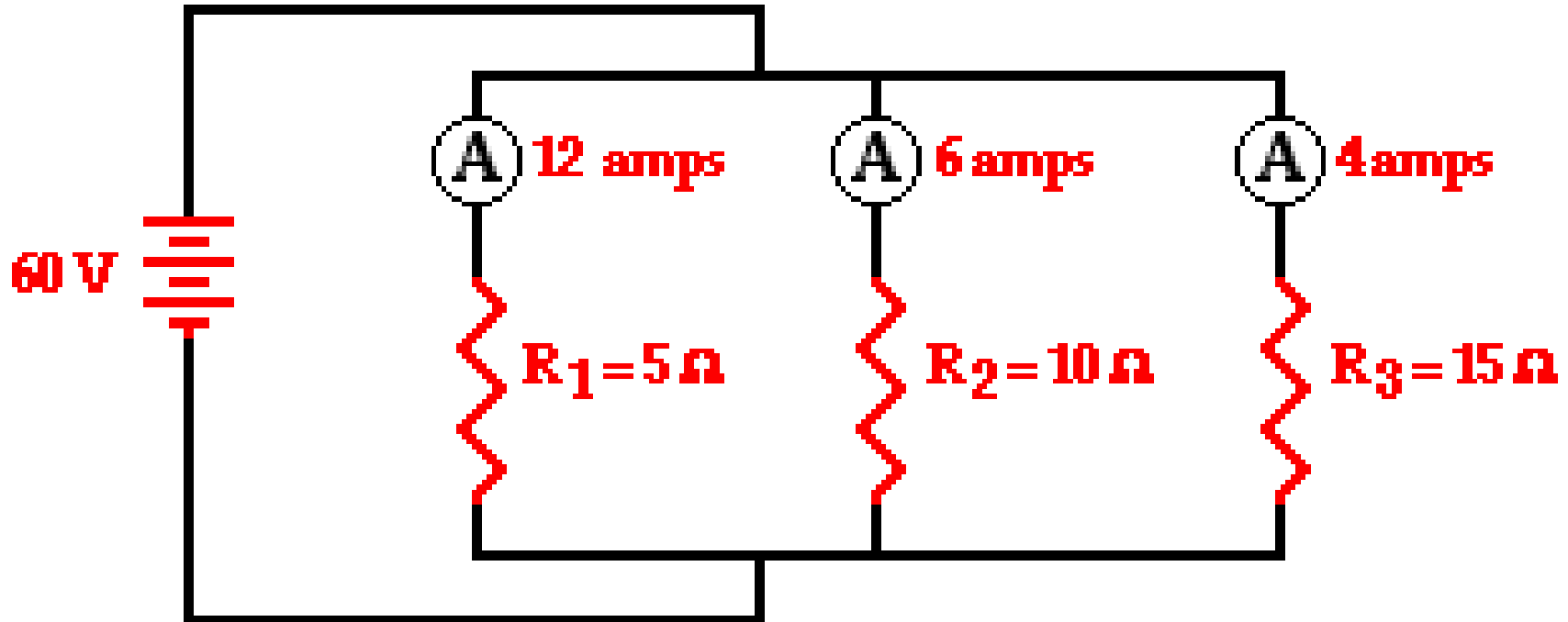

Combination Circuits

An electric circuit that possess BOTH series and parallel circuitry.

- Used most for domestic (homes) and industrial circuits.
- A circuit breaker or fuse is placed in series (nearest the voltage source) in order to shut down the entire circuit.

**Circuit Breaker or
Fuse in series**

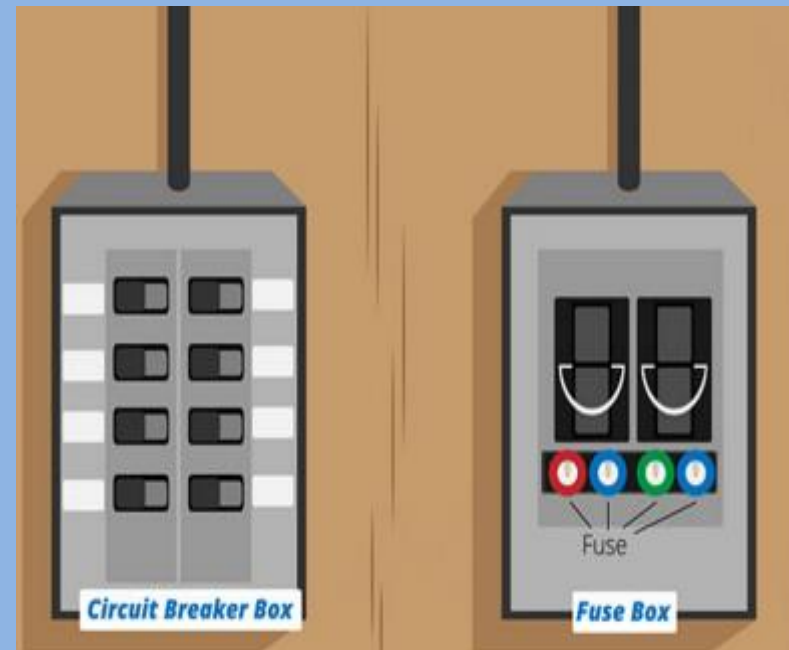
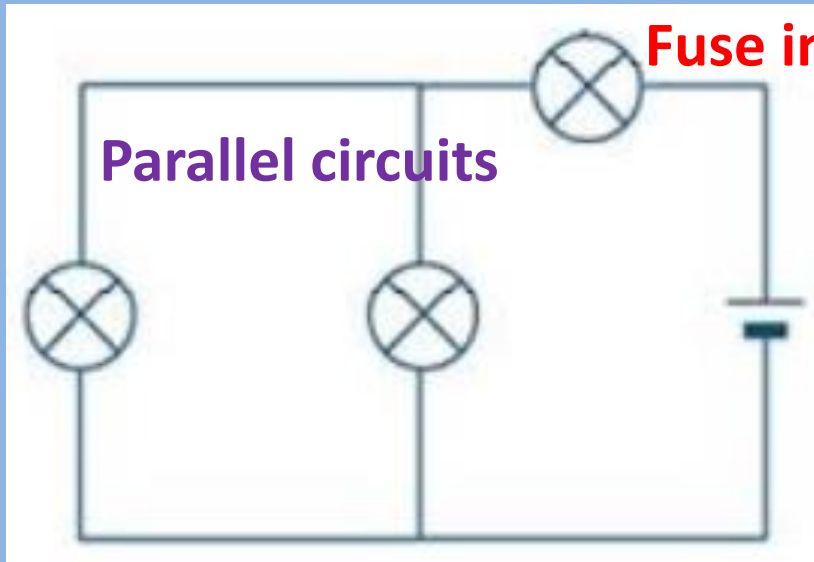

Electrical Safety

Fuses have an internal wire that burns out if a current is too great.



Electrical Safety

Even a small current in your body can cause a painful shock or injury.



Ground-fault circuit interrupter (GFCI)

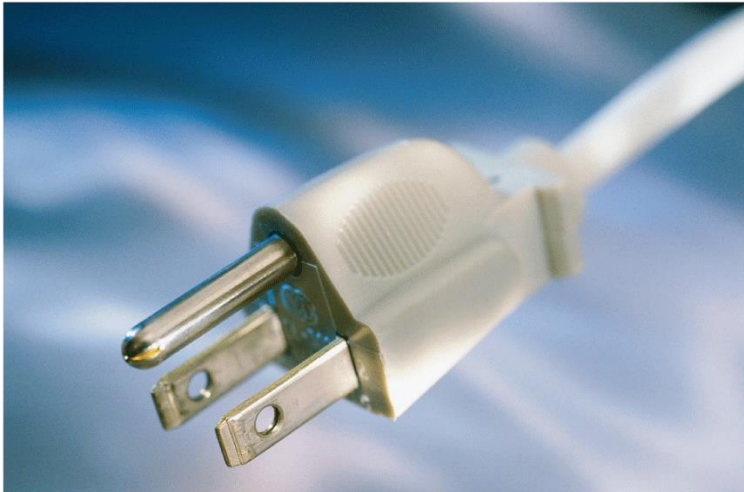

Effect of Current on Human Body

Current Level	Effect
1 mA	Slight tingling sensation
5 mA	Slight shock
6–30 mA	Painful shock; loss of muscular control
50–150 mA	Extreme pain; severe muscular contractions. Breathing stops; death is possible.
1000–4300 mA	Nerve damage; heart stops, death is likely.
10,000 mA	Severe burns; heart stops, death is probable.

Overloading

Circuits that carry more than a safe amount of current are said to be overloaded.

Another phrase used for overloading is a “**short circuit.**”

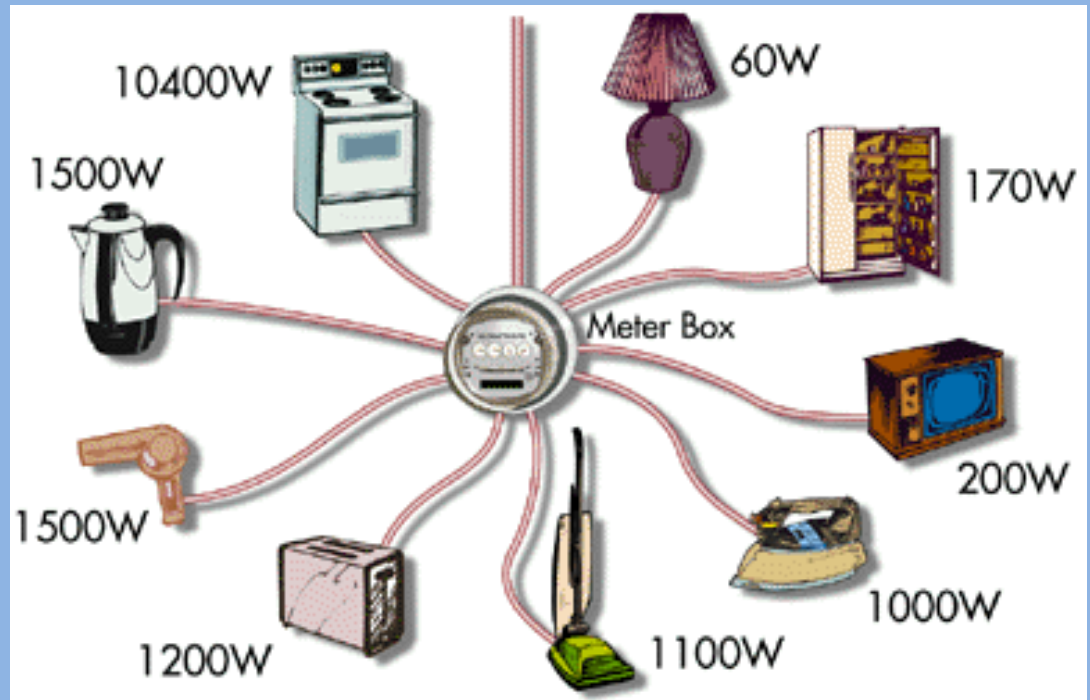
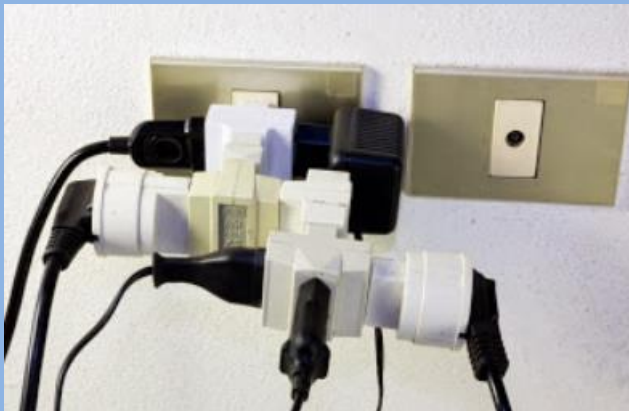

Causes of Overloading



Name some:



"We could have an overload somewhere."

Causes of Overloading



Insulation that separates the wires in a circuit wears away and allows the wires to touch each other.

Loose or corroded wires & connections.

Placing too many “loads” (especially heat producing appliances) on the same circuit.

Many more ...

Sparky! Your mother and I are shocked at your current behavior! Until you learn to **conduct** yourself properly, you're grounded!



SIGNS of Overloading



- Dimming lights, especially if lights dim when you turn on appliances or more lights.
- Buzzing outlets or switches.
- Outlet or switch covers that are warm to the touch.

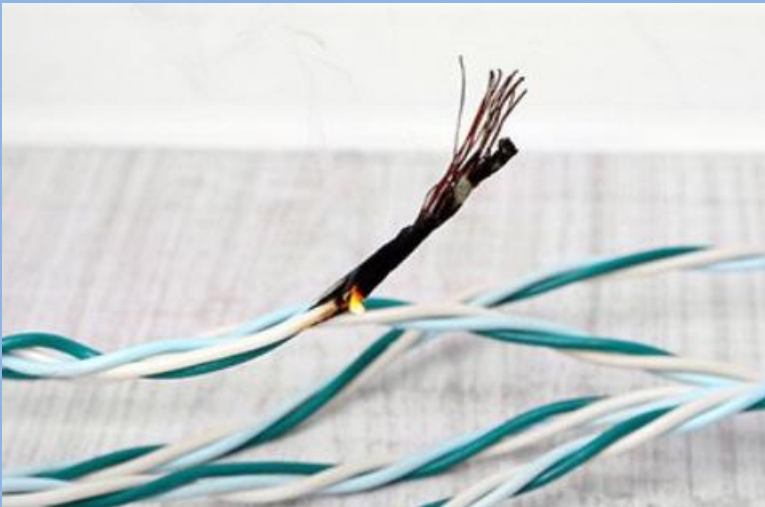

SIGNS of Overloading



- Burning odors from outlets or switches.
- Scorched plugs or outlets.
- Power tools, appliances, or electronics that seem to lack sufficient power.



Demonstrations for Electric Circuits

<http://somup.com/cFX2Yxnjc3> (2:17)

Lighting a Plastic Bulb

The Famous Electric Pickle

<http://somup.com/cFXjenninr>

(2:07) Stephen Spangler

Series & Parallel

Notice that current flows from the **NEGATIVE** terminal of the battery to the positive terminal (**electron flow**). This is because **electrons** flow towards the positive terminal..

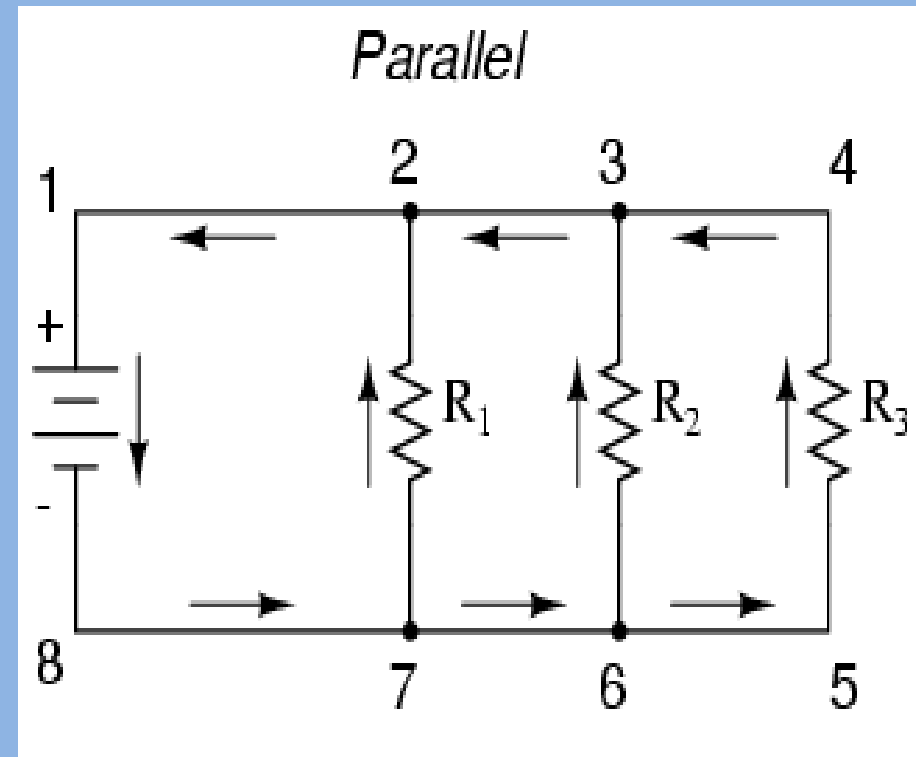
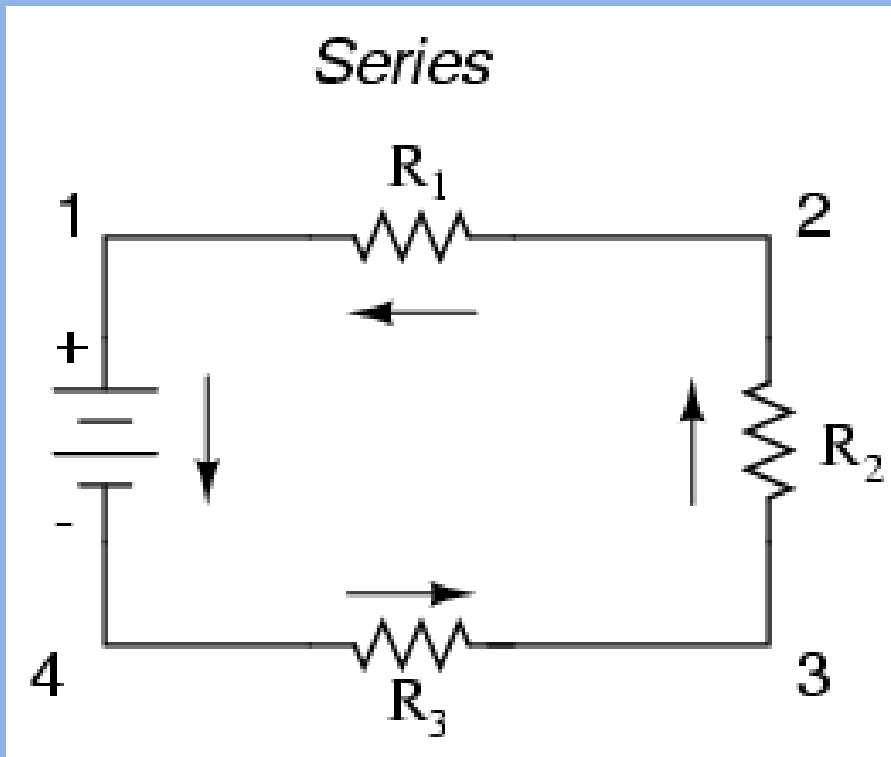

Flow of Charges in a Circuit

Electron flow notation

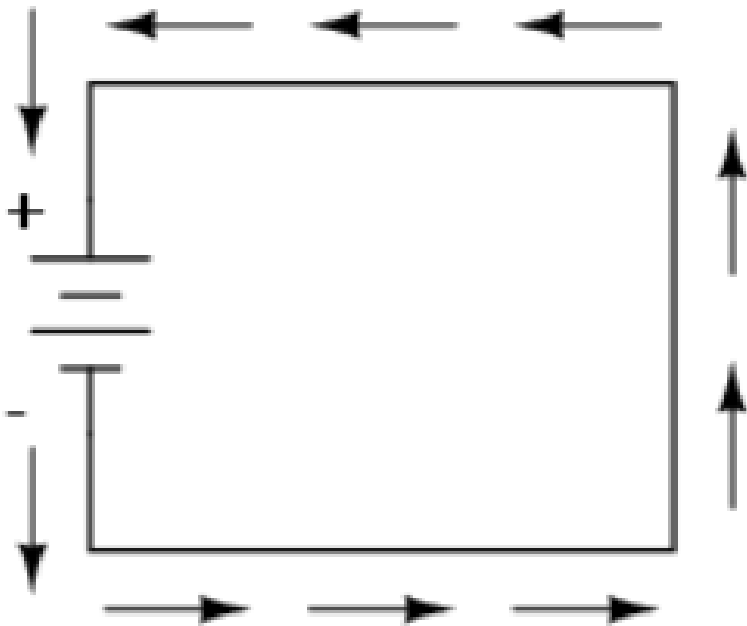

Electric charge moves from the negative (surplus) side of the battery to the positive (deficiency) side.

Flow of Charges in a Circuit → ENRICHMENT

People formerly associated the word “positive” with “surplus” and “negative” with “deficiency” so the standard label for electron charge seems backward. Because of this, many engineers decided to retain the old concept of electricity with “positive” referring to a surplus of charge, and label charge flow (current) accordingly. This became known as *conventional flow* notation:

Conventional flow notation

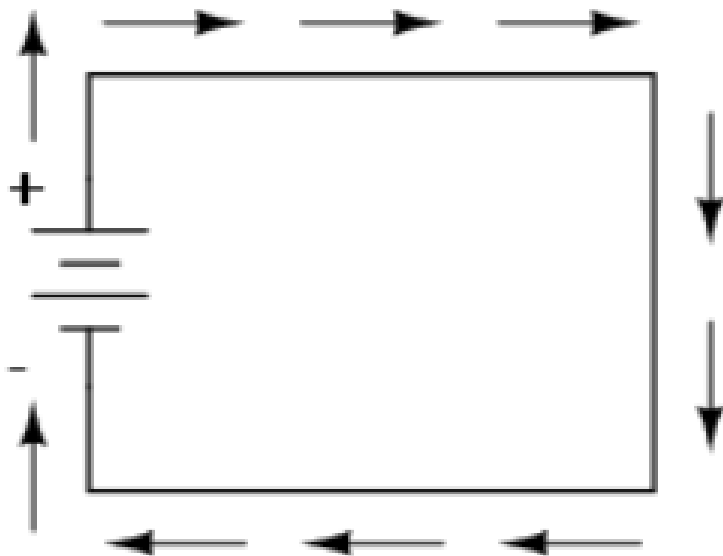

Electric charge moves from the positive (surplus) side of the battery to the negative (deficiency) side.

Flow of Charges in a Circuit

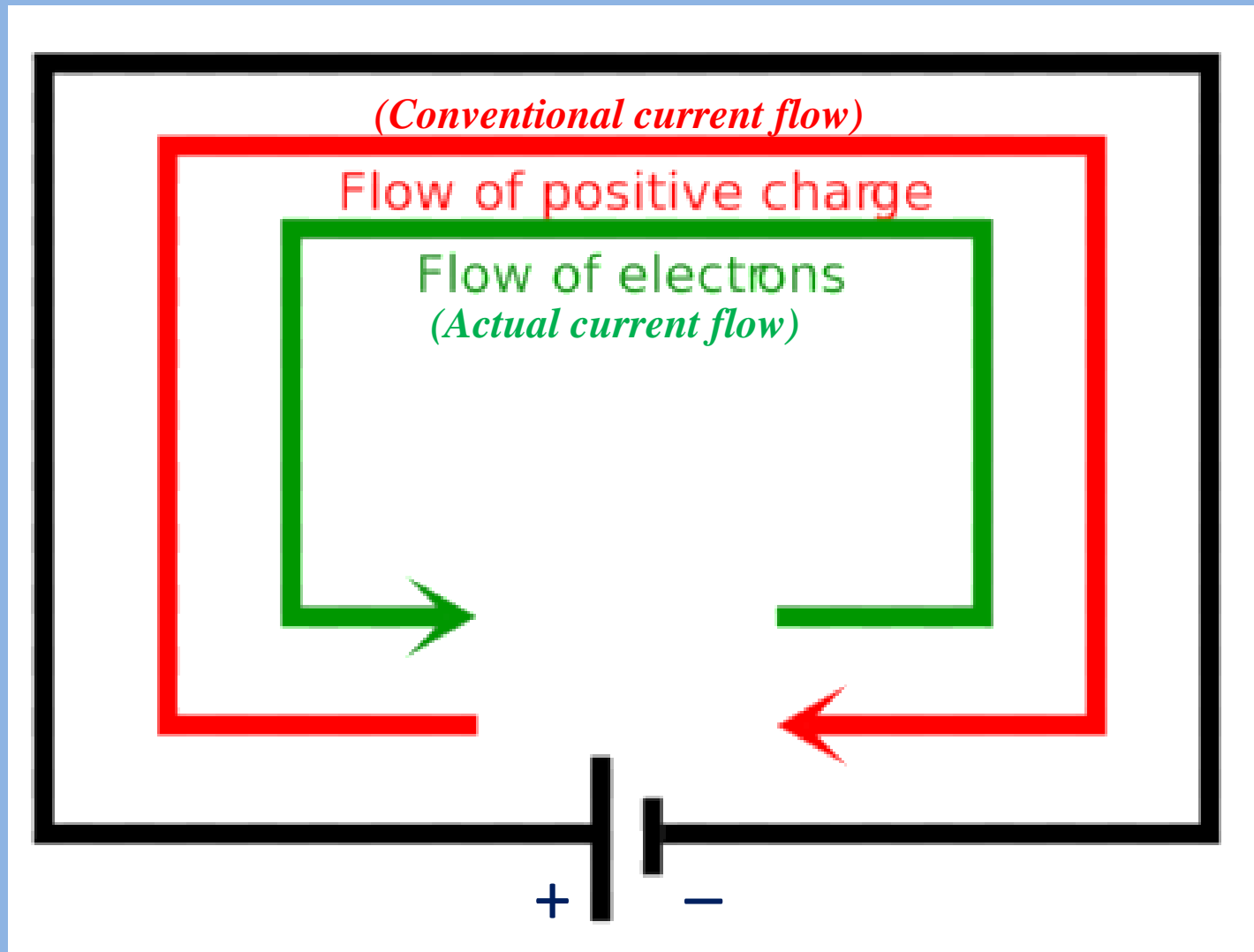

Identify each circuit:

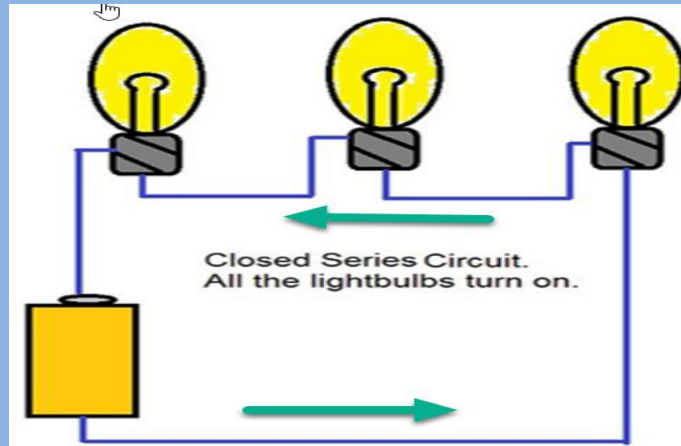
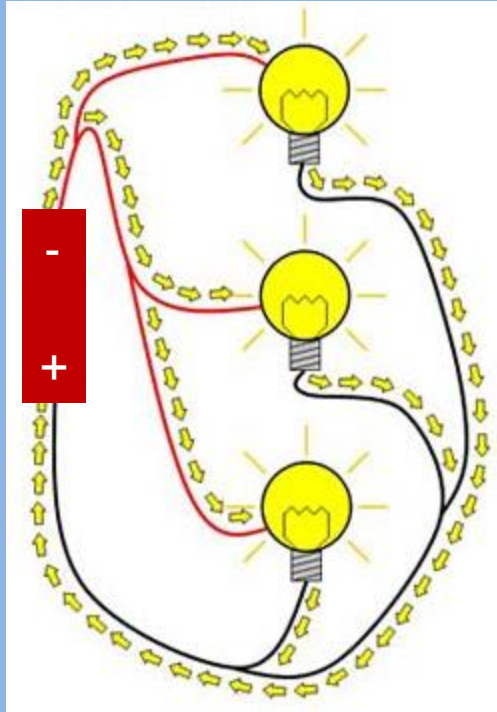

Describe the **current (I)** and **voltage (V)** in the top two circuits

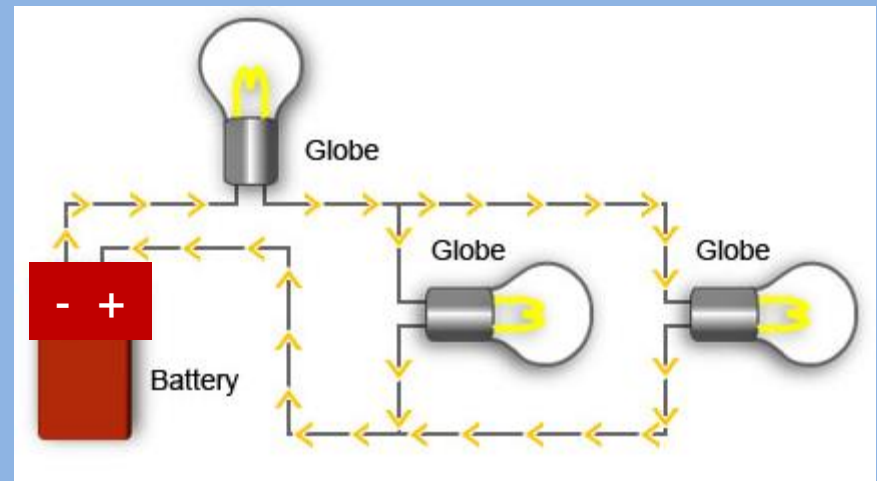

Identify each circuit:

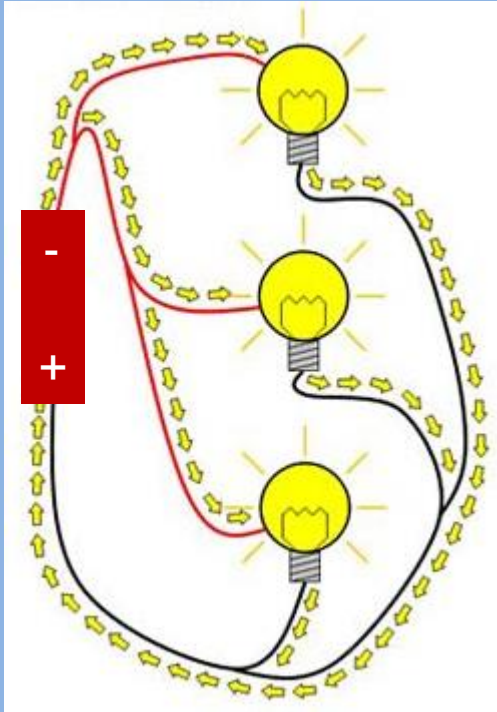

parallel circuit

Same **voltage (V)** throughout the circuit; **current (I)** adds to total in each branch

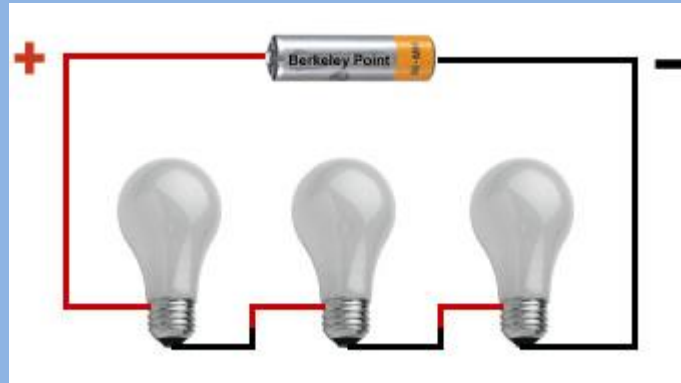

series circuit

Same **current (I)** throughout the circuit; **voltage (V)** adds to total (battery)

combination circuit

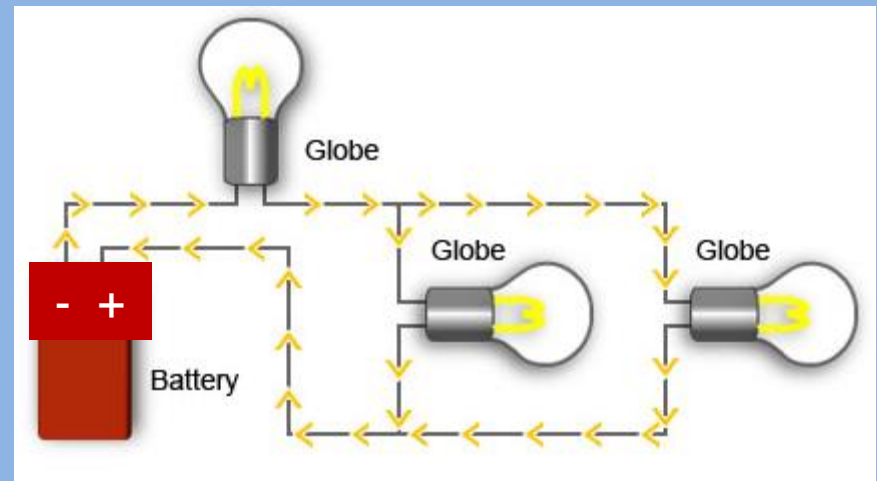

Electrical Power

The rate at which electrical energy is converted to another form of energy is **electric power**. Recall that power is the rate of doing work.

The unit of electric power is the joule per second, or watt (W). Power often is measured in thousands of watts, or kilowatts (kW).

Electrical Energy

$$E = P \times t$$

Electrical Power



An electric oven is connected to a 240-volt line, and it uses 34 amps of current. What is the power used by the oven?

A
G
E
S

A number of light bulbs are connected to an energy source in a series circuit. What will happen to the other bulbs if one of the bulbs burns out?

Nothing will happen.

They will be brighter.

They will be dimmer.

They will turn off.

Electrical Power



An electric oven is connected to a 240-volt line, and it uses 34 amps of current. What is the power used by the oven?

A *power (watts)*

G $V = 240\text{ V}; \text{ current} = 34\text{ A}$

E $P = I \times V$

S $P = I \times V = 34\text{ A} \times 240\text{ V} = 8200\text{ watts}$

(a typical hair dryer uses 1500 watts of power)

A number of light bulbs are connected to an energy source in a series circuit. What will happen to the other bulbs if one of the bulbs burns out?

Nothing will happen.

They will be brighter.

They will be dimmer.

They will turn off.

Power and Energy Calculations

Math Practice

1. A clothes dryer uses about 27 amps of current from a 240-volt line. How much power does it use?

Answer:

Power and Energy Calculations

Math Practice

1. A clothes dryer uses about 27 amps of current from a 240-volt line. How much power does it use?

Answer:

$$P = I \times V = (240 \text{ V})(27 \text{ A}) = 6500 \text{ W}$$

Power and Energy Calculations

Math Practice

2. A camcorder has a power rating of 2.3 watts. If the output voltage from its battery is 7.2 volts, what current does it use?

Answer:

Power and Energy Calculations

Math Practice

2. A camcorder has a power rating of 2.3 watts. If the output voltage from its battery is 7.2 volts, what current does it use?

Answer:

$$I = P/V = (2.3 \text{ W})/(7.2 \text{ V}) = 0.32 \text{ A}$$

Power and Energy Calculations

Math Practice

3. A power tool uses about 12 amps of current and has a power rating of 1440 watts. What voltage does the tool require?

Answer:

Power and Energy Calculations

Math Practice

3. A power tool uses about 12 amps of current and has a power rating of 1440 watts. What voltage does the tool require?

Answer:

$$P = I \times V$$

$$V = P / I = 1440 \text{ W} / 12 \text{ amps} = \mathbf{120 \text{ Volts}}$$

Assessment Questions

1. A number of light bulbs are connected to an energy source in a series circuit. What will happen to the other bulbs if one of the bulbs burns out?
 - a. Nothing will happen.
 - b. They will be brighter.
 - c. They will be dimmer.
 - d. They will turn off.

Assessment Questions

1. A number of light bulbs are connected to an energy source in a series circuit. What will happen to the other bulbs if one of the bulbs burns out?
 - a. Nothing will happen.
 - b. They will be brighter.
 - c. They will be dimmer.
 - d. They will turn off.

ANS: D

Assessment Questions

2. A pair of 15-watt computer speakers are connected to a 12-volt power supply. What is the electric current running through the speakers?
- a. 0.8 A
 - b. 1.25 A
 - c. 12.5 A
 - d. 180 A

Assessment Questions

2. A pair of 15-watt computer speakers are connected to a 12-volt power supply. What is the electric current running through the speakers?
- a. 0.8 A
 - b. 1.25 A
 - c. 12.5 A
 - d. 180 A

ANS: B

Assessment Questions

1. A ground-fault circuit interrupter is a switch that opens to prevent overheating when the current in a circuit is too high.

True

False

Assessment Questions

1. A ground-fault circuit interrupter is a switch that opens to prevent overheating when the current in a circuit is too high.

True

False

ANS: F, circuit breaker

Enrichment Worksheets

- Download the Electric Circuits (Lab)
- Download the Electricity Review worksheet
- Download the Electricity Review 2 worksheet
- Download the Electromagnetism PHET Lab